

## 1 Not English

[5 points] Observe the following example from Tagalog, a language of the Philippines.

- (1) Bumuli ng libro sa tindahan ang maestro.  
Bought the book at shop the teacher  
'The teacher bought the book at the store.'

### 1.1 Headedness

Based on the evidence you can see in (1), do heads seem to precede or follow their complements in Tagalog? Explain your answer.

### 1.2 Tagalog

One aspect of example (1) indicates that at least one type of phrase in Tagalog has its specifier on the right, rather than on the left as in English. Explain what aspect of example (1) indicates this, and which phrase is involved.

### 1.3 Tree

Bringing together your answers for parts 1.1 and 1.2, draw a tree structure for the example in (1). Be sure that your tree conforms to X-bar theory, and that it explains the word order in Tagalog, rather than the word order in the English translation!

## 2 Trees

[20 points (4 per tree)] Draw trees for the following sentences, like the model below. Draw the S-structure, with arrows showing the movement, and with < > around the position from which something moves. For a double movement (like  $V \rightarrow T \rightarrow C$ ), you can draw it as in this tree, with the arrow for the first movement leading to the “trace” of the second movement. Complex heads (like C in the example) should be drawn out. Label silent heads with subscripts (e.g.,  $\emptyset_{Qwh}$ ,  $\emptyset_Q$ ,  $\emptyset_{proper}$ ,  $\emptyset_{mass}$ ,  $\emptyset_{pl}$ ,  $\emptyset_{decl}$ ) or as [+PAST], [-PAST], [-TNS] (for T). You need only draw X' nodes when there is a specifier.

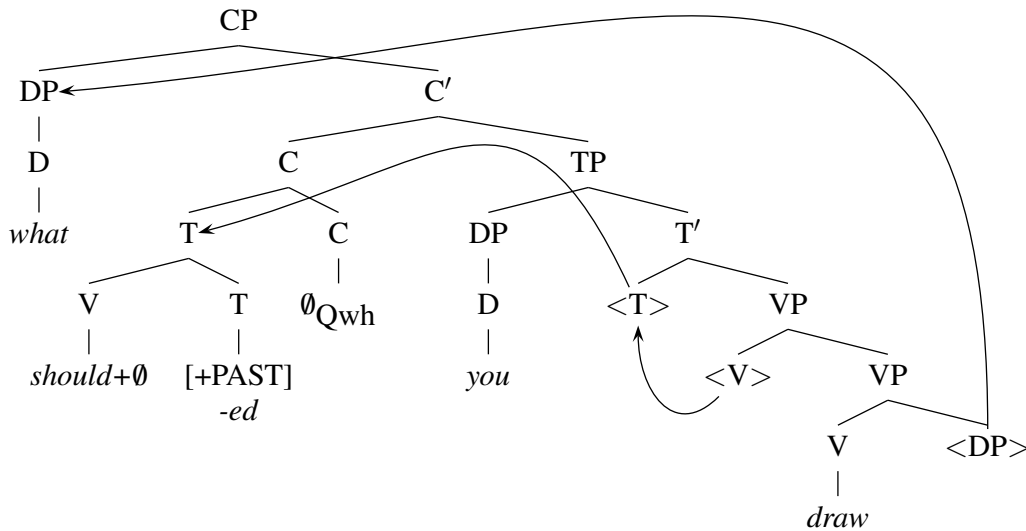

- (2) Who do you think stole the cookies?
- (3) Pat told me where I could buy new cookies.
- (4) I promised not to forget the host's favorite kind of cookies.
- (5) This confused cabbie has been driving in circles for an hour.
- (6) Should a specialized bakery really be closing in the evening on a weekend?

## 3 Necessity's offspring

[5 points] For each description below, provide a sentence matching the description.

- (7) A present tense declarative sentence with an embedded yes-no question.
- (8) A *wh*-question with an embedded past tense declarative sentence.
- (9) A sentence that has PRO in it.
- (10) A sentence containing a ditransitive verb and a mass noun.
- (11) A sentence in which the subject and object are co-referential.